



# **EVAL-RFID**

## **RFID Evaluation Kit**

## Table of Contents

|  |    |
|--|----|
| Purpose.....   | 3  |
| Requirements .....                                       | 3  |
| Connection .....   | 3  |
| Operation.....   | 3  |
|  |    |
| ASCII Configuration.....                                 | 4  |
| SERIAL ASCII Output.....                                 | 4  |
| CR .....   | 4  |
| LF.....  | 4  |
| Checksum calculation .....                               | 4  |
|  |    |
| SETUP OF HYPER-TERMINAL TO DISPLAY RFID TAG NUMBER. .... | 5  |
|  |    |
| RFID Read Range of the PCB module .....                  | 7  |
|  |    |
| Additional RFID PC Data Recording Software.....          | 7  |
|  |    |
| I WANT MORE INFO!..... See the FAQ below.....            | 7  |
|  |    |
| FREQUENTLY ASKED QUESTIONS .....                         | 7  |
|  |    |
| DESIGN YOUR OWN READER.....                              | 8  |
|  |    |
| BILL Of Materials .....                                  | 11 |
|  |    |
| Disclaimer .....   | 11 |

## Adilam – Sokymat RFID ID12 Evaluation Kit

### Purpose

- To demonstrate RFID in action using Sokymat EM Unique RFID tags and the Adilam RFID reader module.
- To simply read RFID tag numbers and transmit them to a PC computer for data collection and storage.
- To expose the user to various tag shapes, styles and applications of RFID tags

### Requirements

- DC Power Supply or battery in the range of 8 to 16 Volts
- PC Computer with an available serial port and Hyper-Terminal or Serial terminal software.
- DB9 Male to DB9 Female serial cable (straight through connection) not supplied.

### Connection

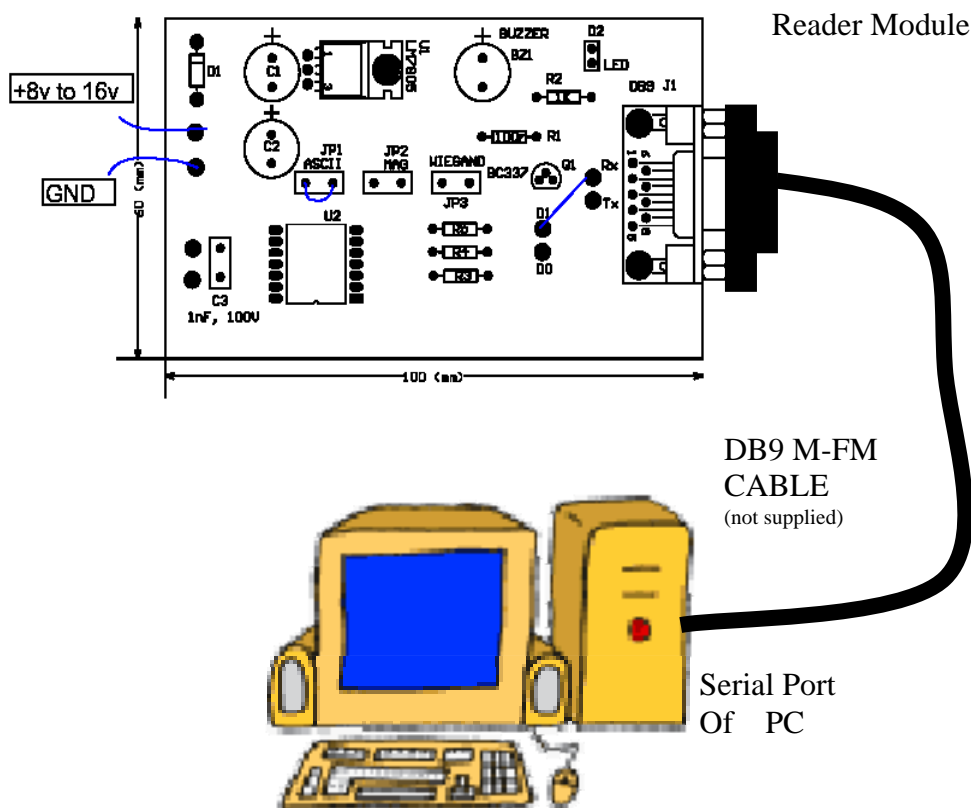

### Operation

The RFID module is supplied with 8v to 16v and draws on average 30 ~ 40mA in the idle state. During a RFID read the current may peak briefly to 60mA

The Reader module comes configured for ASCII 9600 Baud N, 8, 1 output - ready to connect to the serial port of a PC via a DB9 serial cable.

An RFID tag in close proximity to the ID12 RFID reader will have the following action:

1. LED will flash
2. Beep from buzzer
3. The RFID number of the tag is transmitted serially out of pin 2 (Rx) of the DB9 Female connector (J1) of the RFID module.

## ASCII Configuration

The RFID board is shipped configured for ASCII Serial transmission (9600Baud N,8,1)

- D1 - linked to Rx
- JP1 - ASCII is linked JP2 Open, JP3 Open
- R4 - Not fitted
- R5 - Fitted with 100R
- C3 - Not fitted (only for use with ID2 modules - future design)
- ANT - No connection (for use with ID2 modules - future design)

## SERIAL ASCII Output

When the ID12 RFID module detects the RFID tag, the following Serial ASCII data stream is transmitted.

Output Format – Serial ASCII 9600, N,8,1

|                      |  |   |                      |                      |                      |
|----------------------|--|---|----------------------|----------------------|----------------------|
| <b>02</b><br>(1byte) | <b>10 ASCII Hex Data Characters</b><br>(10bytes) | <b>2 ASCII char's Checksum</b><br>(2byte) | <b>CR</b><br>(1byte) | <b>LF</b><br>(1byte) | <b>03</b><br>(1byte) |
|----------------------|--|---|----------------------|----------------------|----------------------|

Total packet length is 16 bytes

Data and Checksum are in ASCII hex format (2 ASCII characters per byte)

Example: Using Hyper-terminal 9600 baud, N, 8,1 (Flow Control = None)

☺041A21EE34E5  
♥

E5 = Checksum

☺ = 02 ASCII

♥ = 03 ASCII

The checksum is the result of the 'exclusive' OR of the binary data bytes

## Checksum calculation

$$04_{\text{hex}} \oplus 1A_{\text{hex}} \oplus 21_{\text{hex}} \oplus EE_{\text{hex}} \oplus 34_{\text{hex}} = E5_{\text{hex}}$$

Thus the ASCII hex values should be converted in to binary before the checksum calculation.

## SETUP OF HYPER-TERMINAL TO DISPLAY RFID TAG NUMBER.

1. Select Hyper-Terminal Setup, ICON and suitable name “RFID Serial COM1”  
Then Press **OK**

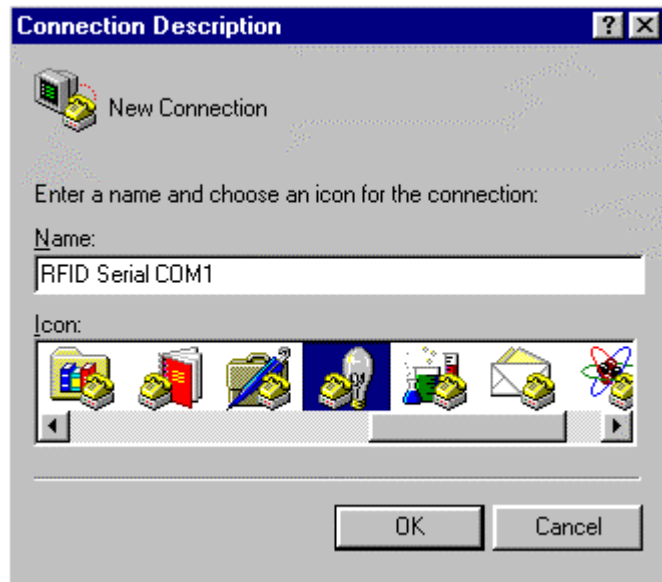

Note:  
Any other terminal emulator program should be suitable to display the RFID data. EG PowerTerm and RealTerm etc

2. Next Window – Select “Direct to COM1” or “Direct to COM2” depending where the serial cable is connected COM1 or COM2.  
Then press **OK**



3. Select Serial Port Parameters - Speed **9600**, No Parity **N**, **8** data bits, **1** Stop Bit. and Flow control **None**. Then press **OK**

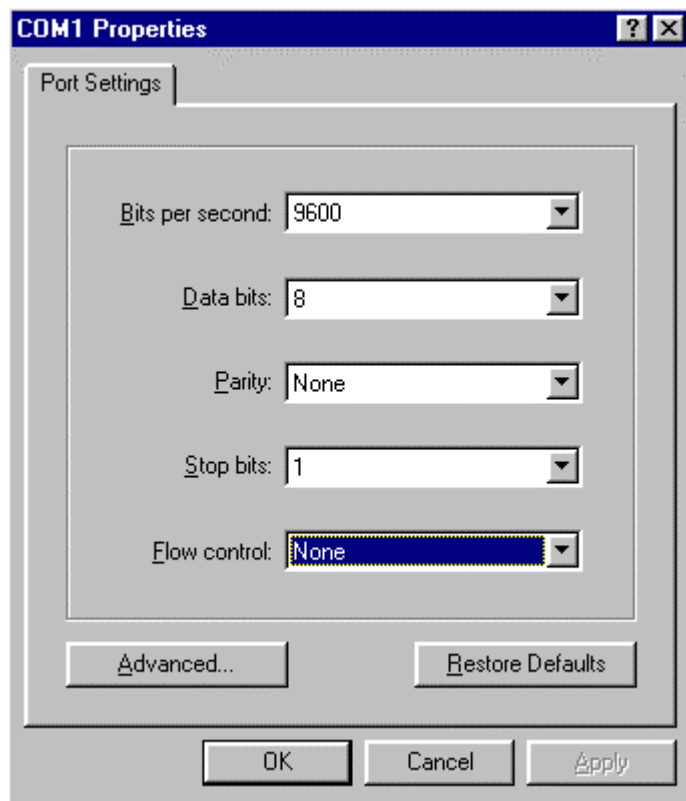

4. Once the RFID module is connected to the serial port of the PC with HyperTerminal – RFID tag number can be displayed.

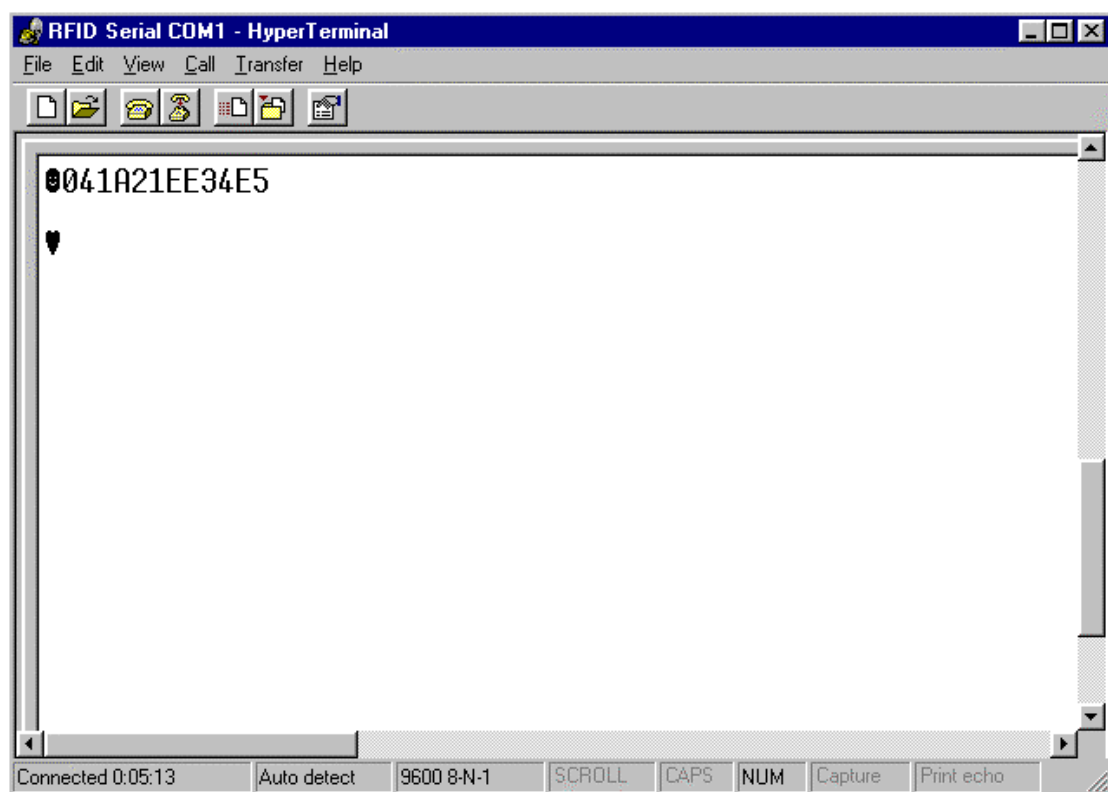

## RFID Read Range of the RFID module

The RFID read range of this module will vary from approx 10mm to 30mm depending on the following factors;

1. The shape and size of the RFID tag. Large Size RFID tags have longer read range (Smaller tags have a smaller RF radiating field)
2. Any metallic objects near the RFID tag or ID12 Module will effectively detune the coils operating frequency and reduce the read range
3. Any electrical interference from electrical equipment will reduce read range.

## Additional RFID PC Data Recording Software

Software is currently available to read the RFID tag from the serial port and log the RFID numbers to a Data file using the MS Visual Basic 6 language on the Adilam RFID Tech Page. [www.adilam.com.au/RFID/rfid.html](http://www.adilam.com.au/RFID/rfid.html)

**I WANT MORE INFO!..... See the FAQ below.**

## FREQUENTLY ASKED QUESTIONS

**Q1:** RFID usually involves coils and loop antennas, however, there isn't any on the RFID module? **A1:** The ID12 Module has an integrated antenna coil

**Q2:** The ID12 module seems to do most of the RFID decoding work, is there a data sheet on the ID12 and is it available for purchase? **A2:** Yes, the data sheet is available from the Adilam Tech Page [www.adilam.com.au/RFID/rfid.html](http://www.adilam.com.au/RFID/rfid.html). Contact Adilam staff for the price and availability of the ID12 Module.

**Q3:** What types of tags are compatible with the RFID Reader module **A3:** Tags in all shapes and sizes that are fitted with the Sokymat EM Unique read only Chip.

**Q4:** What frequency does this Sokymat EM Unique RFID system use? **A4:** 125KHz which is very popular RFID low frequency. The modulation method is ASK Manchester encoded. Additional information is available from Adilam Engineering.

**Q5:** I have particular RFID design/application in mind, what is the minimum order qty (MOQ) for volume qty's of RFID tags? **A5:** The MOQ is dependant on the tag type. Please contact Adilam sales for MOQ and pricing inquiries.

**Q6:** What's inside the ID12 module? **A6:** The ID12 has a 125KHz Osc, Coil, amplitude detection system (to demodulate the data stream) and micro-controller to decode the data stream and transmit it at 9600Bd serially.

**Q7:** How can I design a RFID system that stores the RFID tags into non-volatile memory, to use in an access control system? **A7:** By using a micro controller with a serial / UART and on board non-volatile memory (EEPROM) such as the Philips P89LPC932. Contact Adilam Engineering for further information

**Q8:** An ID2 module was mentioned in this document, how is the ID2 module different to the ID12 module? **A8:** Basically the ID2 requires an external coil of your

own design. This can improve the read range or assist in reading RFID tags in difficult locations, were the ID12 cannot easily read the RFID tag. Please visit [www.adilam.com.au/RFID/rfid.html](http://www.adilam.com.au/RFID/rfid.html) for a data sheet on the ID2 and ID12 modules.

**Q9:** Why does C3 need to be 100V rated, when using the ID2 module? **A9:** With a resonant 125KHz external coil, the induced volts are quite large.

**Q10:** There are 3 jumpers J1 , J2 and J3, how do they effect the operation of the ID12 module? **A10:** On power up the ID12 looks at the state of the jumpers to determine the output mode, J1 = ASCII 9600bd, J2 = magnetic stripe emulation, J3 = Wiegand. Only one jumper at a time can be used.

**Q11:** What is Magnetic Stripe Emulation? **A11:** Please refer to the ID12 data sheet available on [www.adilam.com.au/RFID/rfid.html](http://www.adilam.com.au/RFID/rfid.html). Basically, when an RFID tag is read it will send out a serial stream that is in the format of a magnetic card reader.

**Q12:** What is Wiegand Output? This is an access control transmission protocol, used in alarm and access control systems. When this output is selected, data transmitted from the ID12 used D1 and D0 (logic 1 and logic 0) . One line for each logic level. More information is available on the Adilam web site [www.adilam.com.au/RFID/rfid.html](http://www.adilam.com.au/RFID/rfid.html).

**Q13:** Can I get clearer pictures of the Schematic Diagram and PCB of the Reader design? **A13:** Yes, These are available on [www.adilam.com.au/RFID/rfid.html](http://www.adilam.com.au/RFID/rfid.html) in Adobe Acrobat format.

**Q14:** Can I get Protel schematic and PCB files for this design? **A14:** Yes, these files are available from [www.adilam.com.au/RFID/rfid.html](http://www.adilam.com.au/RFID/rfid.html).

**Q15:** This is an evaluation kit, Are there any complete commercial RFID readers available from Adilam? **A15:** Yes, please visit [www.adialm.com.au/techpage/RFID](http://www.adialm.com.au/techpage/RFID) Adilam has a selection of RFID readers.

## DESIGN YOUR OWN READER

**Q16:** I want to design my own discrete RFID, rather than use the ID12 module so I have control over the data stream. What components can Adilam supply?

**A16:** Adilam can supply the following components

- RFID reader IC - Sokymat's **Tag Reader IC** and Philips – **Hitag Reader IC**
- Philips 80c51 micro-controllers ranging from 8pin to 64 pins
- Complete range of passive components R, C and L
- LED's
- Philips regulators and system monitoring IC's
- Full Range of connector

Contact Adilam for additional information on available parts.

# Eval RFID Schematic Diagram

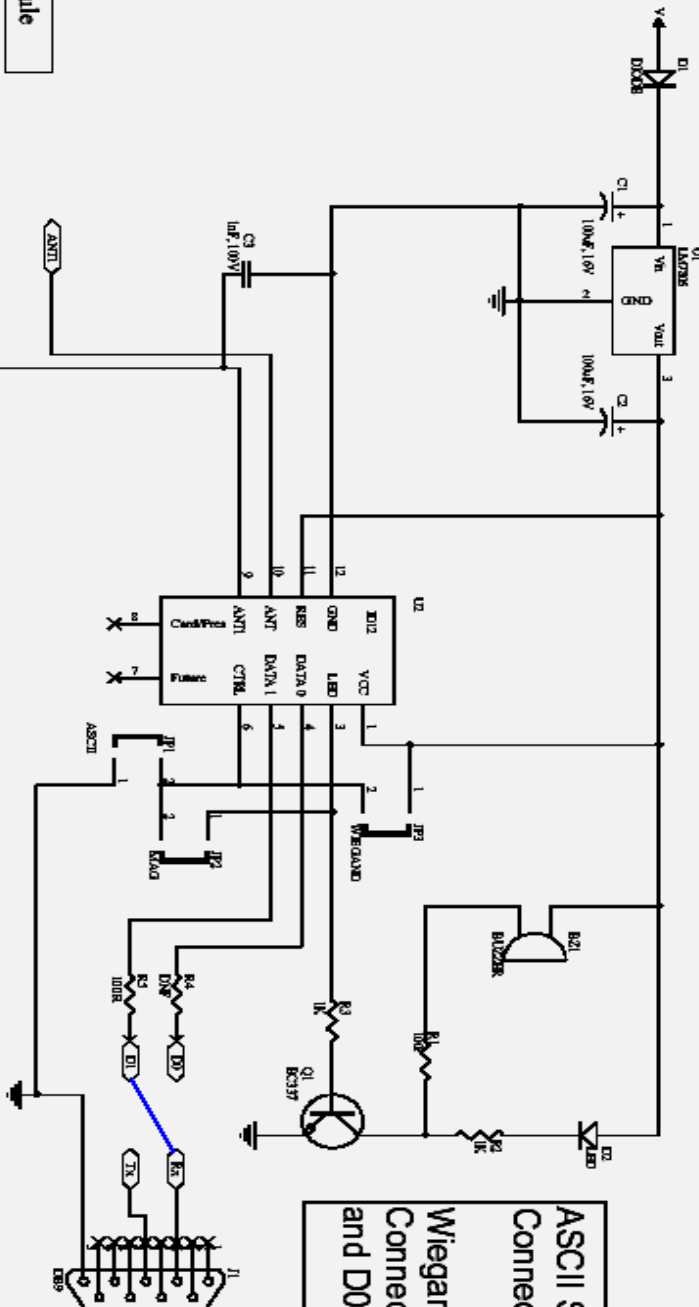

Bottom of ID12 Module

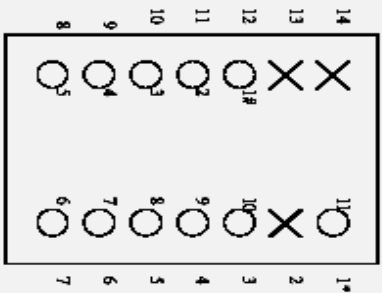

# Inside ID12  
Pins 1 - 11

\* Outside ID12 PCB  
Pins 1 - 14 to suit PCB

Select RFID output via only 1 jumper selection

ASCII Output - Serial - 9600Bd, N, 8, 1

WIEGAND - 26bit Wiegand output

MAG - magnetic stripe emulation

ASCII Selection  
Connect D1 to Rx  
Wiegand  
Connect D1 to Rx  
and D0 to Tx

Select D0 or D1 to either Tx or Rx

D0 - DATA 0 - TTL Level data output inverted

D1 - DATA 1 - TTL Level data output non-inverted

|   |        |       |       |
|---|--------|-------|-------|
| Title   |        |       |       |
| RFID Eval Kit Ver D - Adilam Electronics PartNo Eval_KitD_D012    |        |       |       |
| Rev   | Number | Issue | Known |
| B   |        | 1     | 01    |
| Date: 18 Nov 2005   |        |       |       |
| File: C:\My Documents\adilam\RFID\KITD012\RFID Eval KitD_D012.dwg |        |       |       |

# Eval RFID PCB Layout

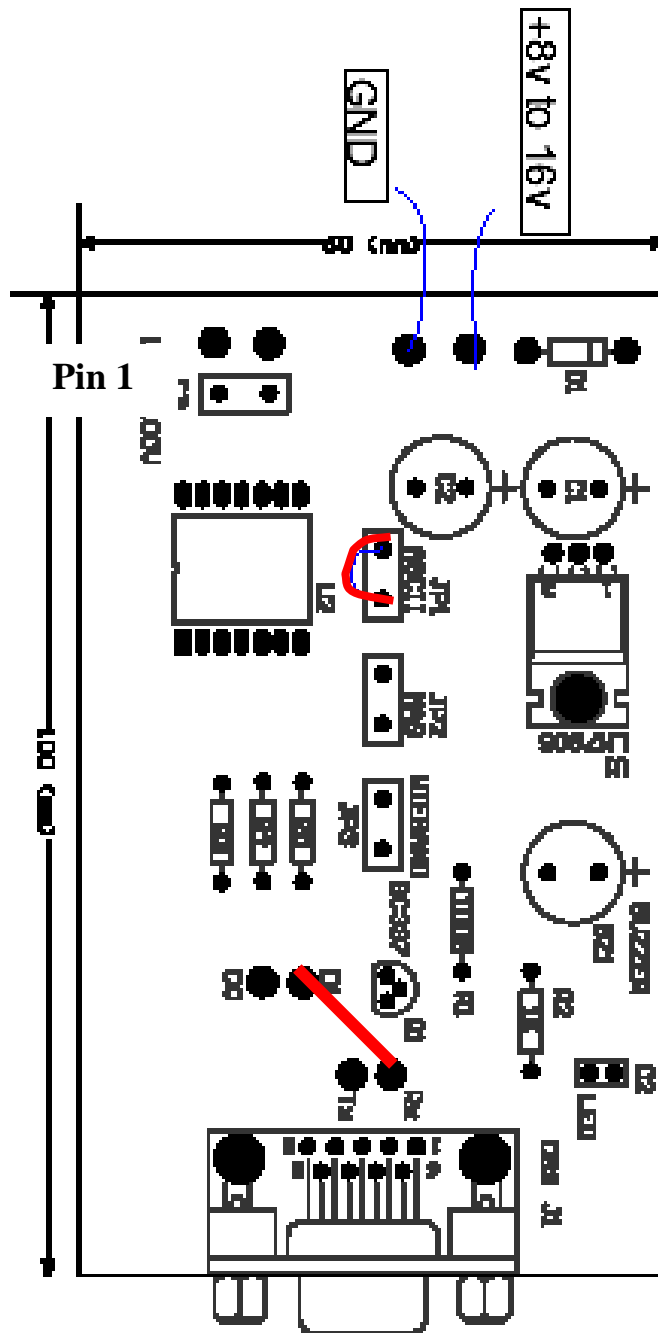

## BILL Of Materials

| Description               | Designator | Footprint | LibRef        | PartType    |
|---------------------------|------------|-----------|---------------|-------------|
| LM7805 Volt Reg           | U1         | TO220H    | VOLTREG       | LM7805      |
| Capacitor                 | C1         | RB-.2/.4  | CAPACITOR POL | 100uF, 25v  |
| Capacitor                 | C2         | RB-.2/.4  | CAPACITOR POL | 100uF, 25v  |
| RF ID Module              | U2         | ID12      | ID12          | ID12        |
| Capacitor                 | C3         | RAD-0.2   | CAP           | 1nF, 100V   |
| Buzzer                    | BZ1        | RB.7.     | BUZZER        | BUZZER      |
| 100R 1/4W                 | R1         | AXIAL-0.4 | RES1          | 100r        |
| 1K 1/4W                   | R2         | AXIAL-0.4 | RES1          | 1K          |
| 5mm LED                   | D2         | RAD0.1    | DIODE         | LED         |
| BC337 Transistor / BC 547 | Q1         | TO92A     | NPN           | BC337       |
| 1K 1/4W                   | R3         | AXIAL-0.4 | RES1          | 1K          |
| 1K 1/4W                   | R4         | AXIAL-0.4 | RES1          | 100r        |
| 0R Wire link – Jumper     | R5         | AXIAL-0.4 | RES1          | 0R          |
| DB9 FM R/A                | J1         | DB9FL     | DB9           | DB9         |
| Jumper – Wire Link        | JP1        | RAD0.2    | JUMPER        | ASCII       |
| Jumper – Wire Link        | JP2        | RAD0.2    | JUMPER        | MAG         |
| Jumper – Wire Link        | JP3        | RAD0.2    | JUMPER        | WIEGAND     |
| RFID ID12                 | PCB        | PCB       |               | ID12 Module |
| Power Wire                | RED/BLACK  |           |               | WIRE        |
| Diode                     | D1         |           | DIODE         | 1N4004      |

## Disclaimer

The information presented in this document does not form part of any quotation or contract, is believed to be accurate and reliable and may be changed without notice. This kit is to be used as a reference design only and not part of a actual product design. The publisher for any consequence of its use will accept no liability.